



# 2,500 GPD R.O. SYSTEM

## GENERAL SPECIFICATIONS

|                     |               |
|---------------------|---------------|
| Product SKU         | CQE-CO-02027R |
| Gallons Per Day*    | 2,500 GPD     |
| Gallons Per Minute* | 1.74 GPM      |
| Approx. Weight      | 180 lbs.      |
| Recovery**          | 33% - 50%     |
| Operating Pressure  | 150 psi       |
| Maximum TDS         | 2,000 ppm     |
| Chlorine Tolerance  | <1 ppm        |
| Turbidity           | 1 NTU         |

## MECHANICAL SPECIFICATIONS

|                 |         |
|-----------------|---------|
| Motor HP        | 3/4     |
| Voltage (Volts) | 110/220 |
| Hertz           | 50/60   |

## CONNECTION SPECIFICATIONS

|                    |      |
|--------------------|------|
| Feed Connection    | 1"   |
| Product Connection | 3/8" |
| Waste Connection   | 3/8" |

## MEMBRANE SPECIFICATIONS

Membranes 2.5" x 40" Qty. 3

R.O. Prefiltration 5" x 20" Qty. 2

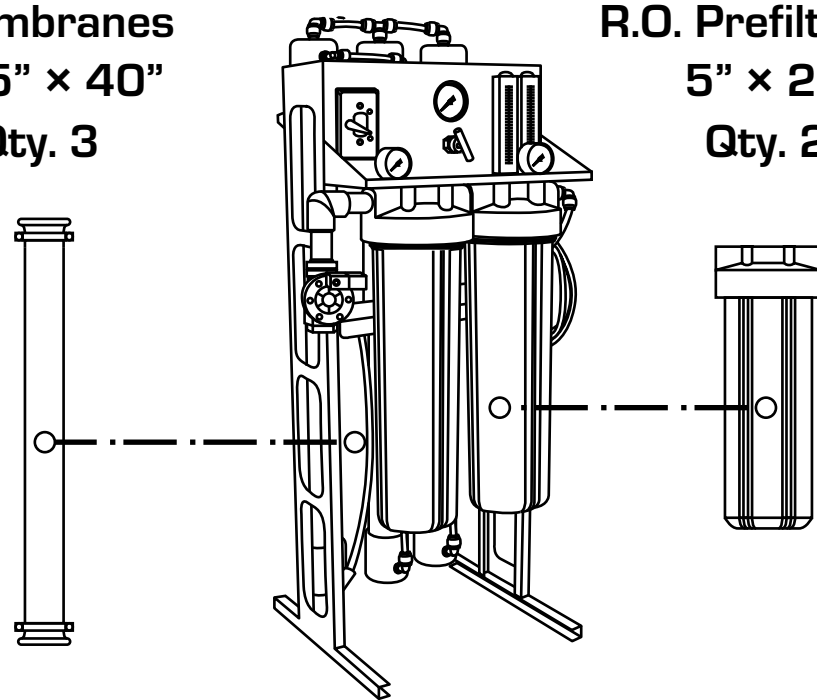

| FLOW KEY                 |  |
|--------------------------|--|
| Influent Water Flow      |  |
| R.O. Treated Water Flow  |  |
| Remineralized Water Flow |  |
| Waste Water Flow         |  |
| Backwash Flow            |  |
| Brine Draw Flow          |  |

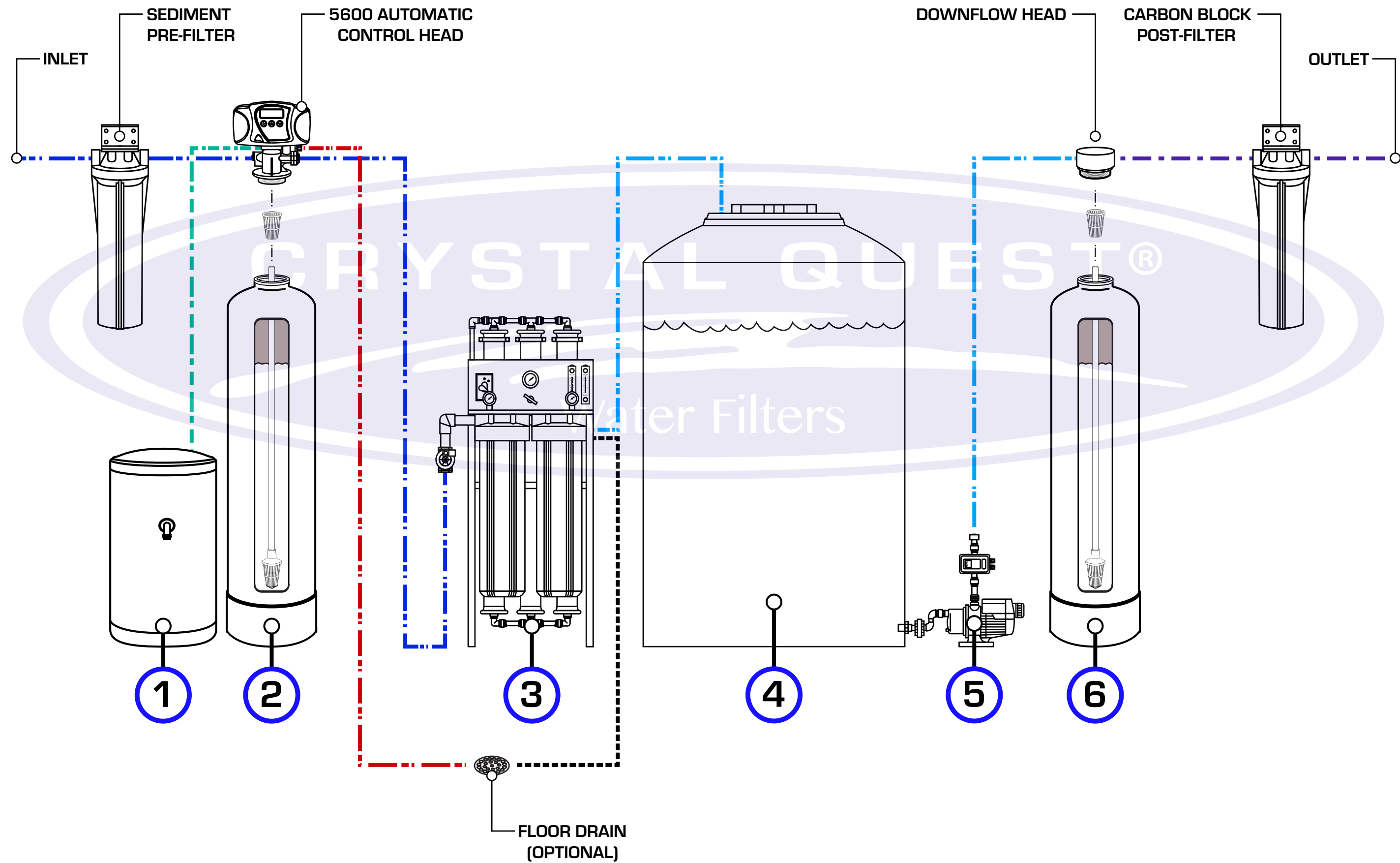

| ORDER OF OPERATION: | PRODUCT SKU:          | DIMENSIONS:   | COMMENTS:             | UNLESS OTHERWISE SPECIFIED:   | DATE: 03/14/2019 DRAWN BY: DUSTIN  |
|---------------------|-----------------------|---------------|-----------------------|---|--|
| 1                   | SOFTENER BRINE TANK   | CQE-PT-03359  | D 18" x H 33"         | DIMENSIONS ARE IN INCHES.<br>DRAWING IS NOT TO SCALE.                   | TITLE:<br>2,500 GPD R.O. SYSTEM W/ SOFTENER,<br>REMINERALIZER & 165 GALLON STORAGE |
| 2                   | 2.0 WATER SOFTENER    | CQE-WH-01124  | D 12" x H 52"         |   |  |
| 3                   | 2,500 GPD R.O. SYSTEM | CQE-CO-02027R | L 19" x W 23" x H 46" | DIMENSION KEY:<br>L → LENGTH<br>W → WIDTH<br>H → HEIGHT<br>D → DIAMETER | SIZE C<br>DWG. NO. 1<br>REV # A<br>SCALE: 1:20 WEIGHT: SHEET 1 OF 1                |
| 4                   | 165 GAL STORAGE TANK  | CQE-ST-00401  | D 31" x H 56"         |   |  |
| 5                   | REBOOSTERIZER PUMP    | CQE-PM-00203  | L 18" x W 11" x H 14" |   |  |
| 6                   | 2.0 REMINERALIZER     | CQE-WH-08008  | D 12" x H 52"         |   |  |

• GPD IS PER 24-HOUR CYCLE.  
• RECOVERY RATIO MAY VARY FROM 33% - 50% AND UP TO 75% IF SYSTEM PROJECTIONS HAVE BEEN PROVIDED

THE INFORMATION CONTAINED IN THIS DRAWING IS THE SOLE PROPERTY OF CRYSTAL QUEST. ANY REPRODUCTION IN PART OR AS A WHOLE WITHOUT THE WRITTEN PERMISSION OF CRYSTAL QUEST IS STRICTLY PROHIBITED.