



# Fluoride Removal System

## SPECIFICATIONS

Approx. Capacity	10,000,000 Gallons
Tank Material	Fiberglass
Backwash	Automatic
Media Type	Fluoride Removal
Media Amount	600 lbs.
Gravel (Quartz)	250 lbs.
Shipping Weight	2,400 lbs.
Space Required	L 40" x W 48" x H 95"

## SYSTEM FLOWRATES

GALLONS PER MINUTE\*

Service Flow	185 GPM
Peak Flow	250 GPM
Backwash Flow	35 GPM

## STANDARD LINE/PORT SIZES

Inlet/Outlet	3"
Drain Port	2"
Neck Opening	4"

## COMPONENT LIST

①	3900 Control Head	CQE-CV-03900
②	Top Distributor	CQE-PT-03105
③	20cu Resin Tank	CQE-PT-04013
④	Fluoride Blend	CQE-RM-05021
⑤	Bottom Distributor	CQE-PT-03417
⑥	Quartz Support Bed	CQE-RM-05004
⑦	---	---
⑧	---	---
⑨	---	---
⑩	---	---

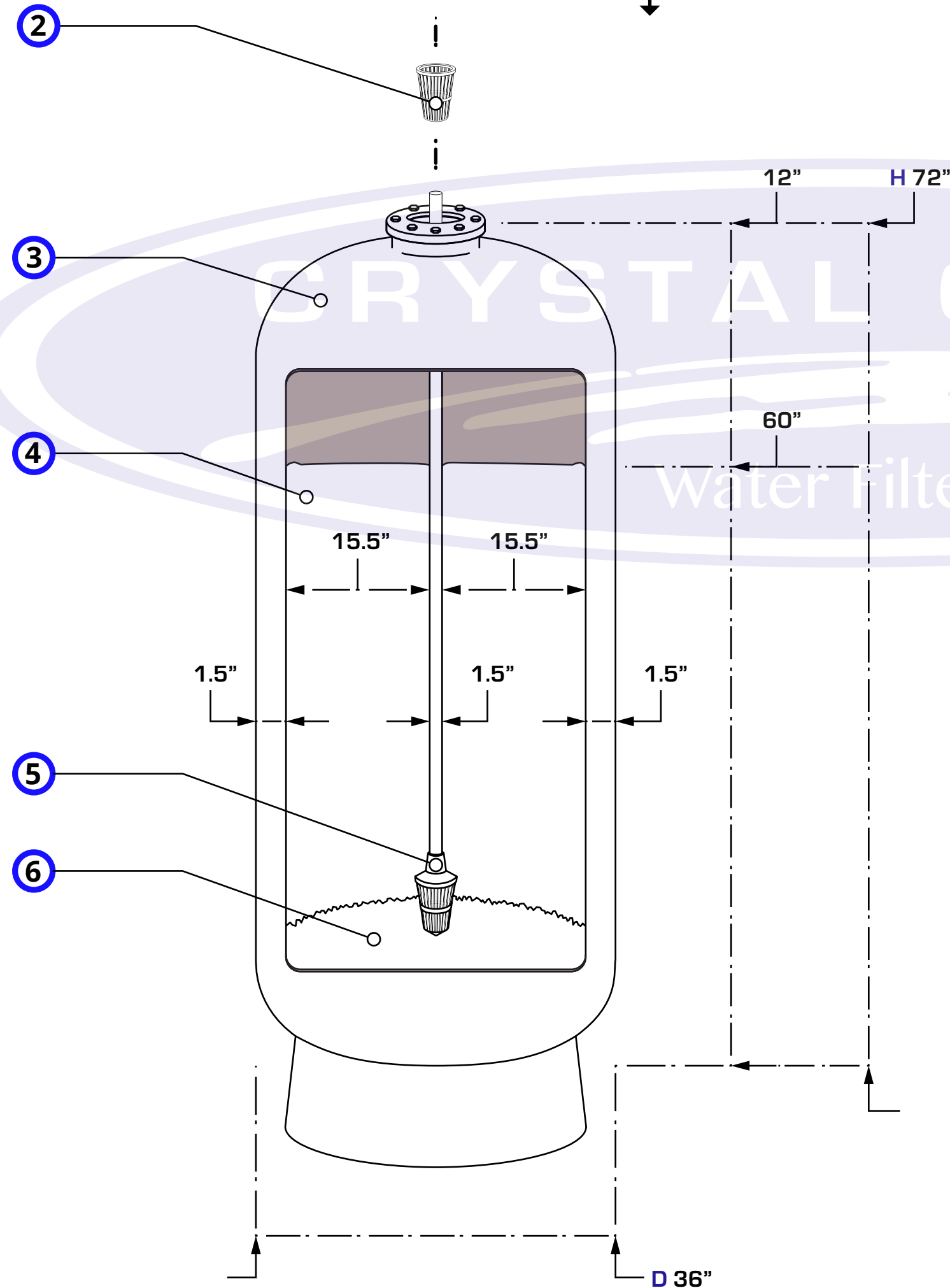
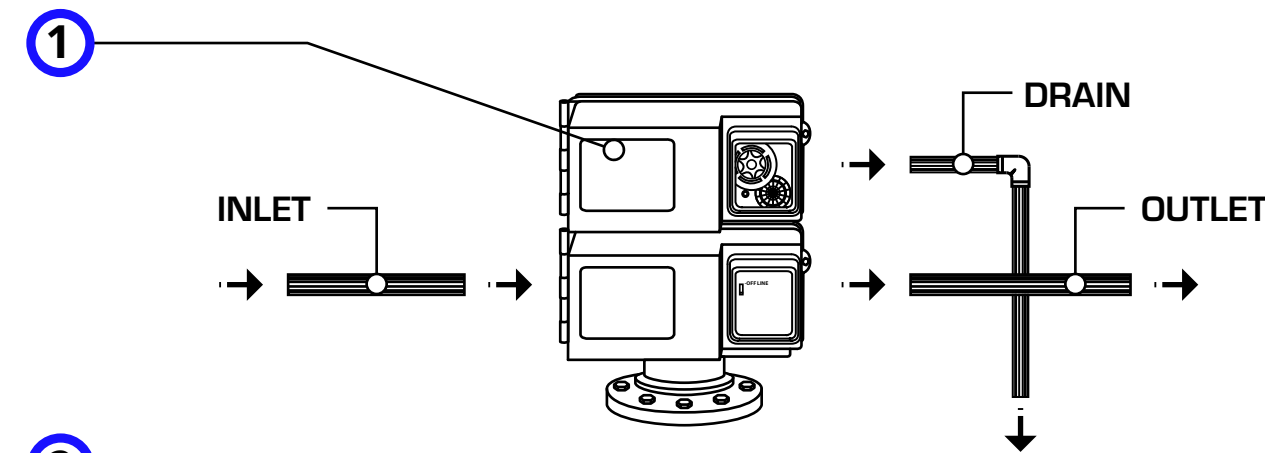

## FLOW KEY

Influent Water Flow	
Filtered Water Flow	
Waste Water Flow	
Backwash Flow	

## FLOW DIAGRAM

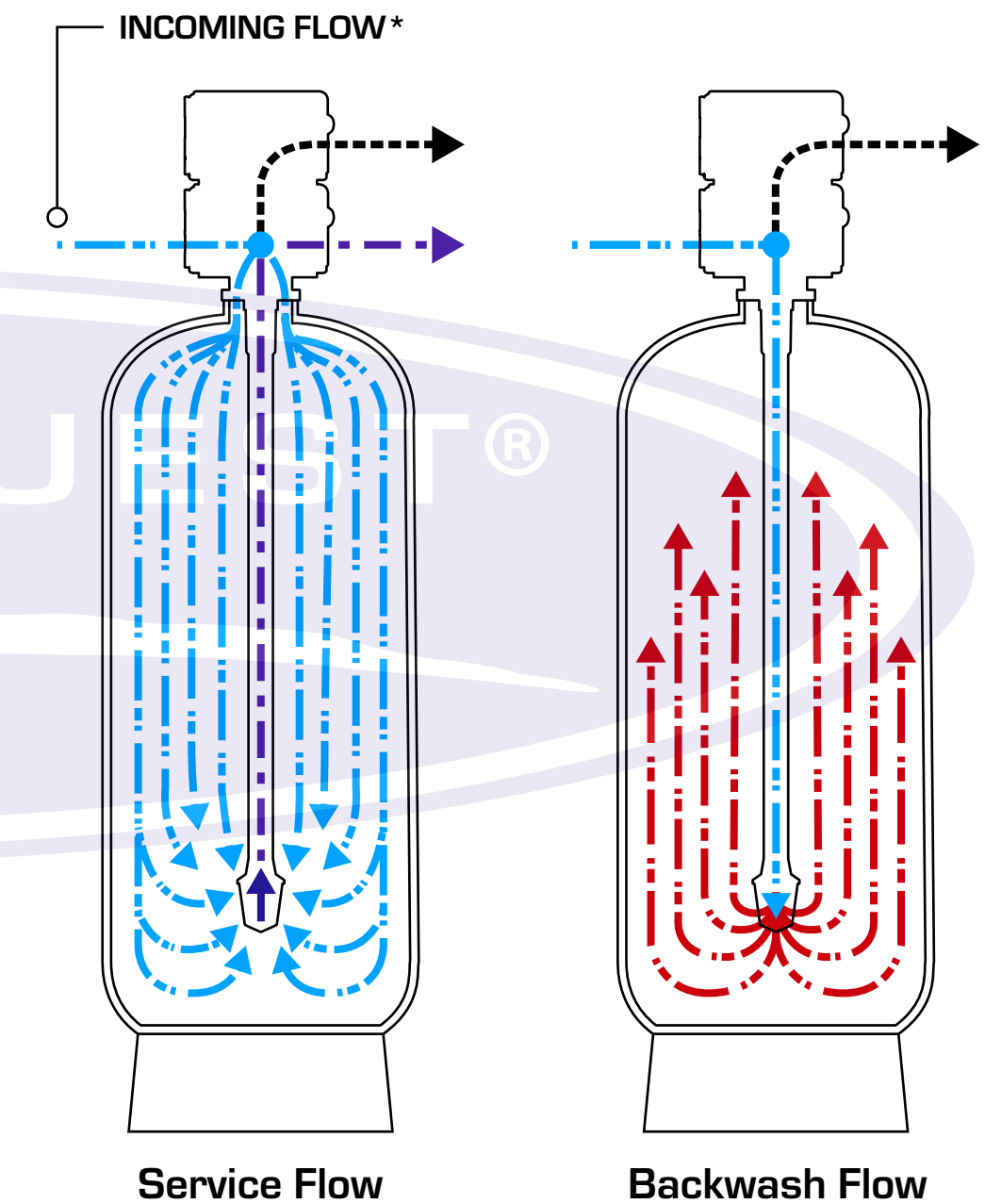

## MEDIA SPECIFICATIONS

Name	Fluoride Multimedia
SKU	CQE-RM-05021
Density	40 lbs per cu.

## CERTIFICATIONS



## PHYSICAL CHARACTERISTICS

Approx. Color	Black/White
Granular Surface Area	12 x 40 Mesh

ORDER OF OPERATION:	PRODUCT SKU:	DIMENSIONS:	COMMENTS:
FLUORIDE REMOVAL SYSTEM	CQE-CO-02080f	D 36" x H 72"	• CONNECTIONS ARE 3" STANDARD
---	---	---	THE INFORMATION CONTAINED IN THIS DRAWING IS THE SOLE PROPERTY OF CRYSTAL QUEST. ANY REPRODUCTION IN PART OR AS A WHOLE WITHOUT THE WRITTEN PERMISSION OF CRYSTAL QUEST IS STRICTLY PROHIBITED.
---	---	---	
---	---	---	
---	---	---	
---	---	---	

UNLESS OTHERWISE SPECIFIED:	DATE: 07/24/19		
DIMENSIONS ARE IN INCHES.	TITLE:		
DRAWING IS NOT TO SCALE.	20 CUBE/185 GPM COMMERCIAL FLUORIDE REMOVAL WATER FILTRATION SYSTEM		
DIMENSION KEY:			
L		LENGTH	SIZE C DWG. NO. 1 REV # A
W		WIDTH	
H		HEIGHT	
D		DIAMETER	
SCALE: 1:20		WEIGHT:	SHEET 1 OF 1