



# 1,500 GPD R.O. SYSTEM

## GENERAL SPECIFICATIONS

Product SKU	CQE-CO-02026R
Gallons Per Day*	1,500 GPD
Approx. Dimensions	L 14" x W 20" x H 46"
Approx. Weight	160 lbs.
Recovery**	33% - 50%
Operating Pressure	150 psi
Maximum TDS	2,000 ppm
Chlorine Tolerance	<1 ppm
Turbidity	1 NTU

## MECHANICAL SPECIFICATIONS

Motor HP	1.5
Voltage (Volts)	110/220
Hertz	50/60

## CONNECTION SPECIFICATIONS

Feed Connection	1"
Product Connection	3/8"
Waste Connection	3/8"

## MEMBRANE SPECIFICATIONS

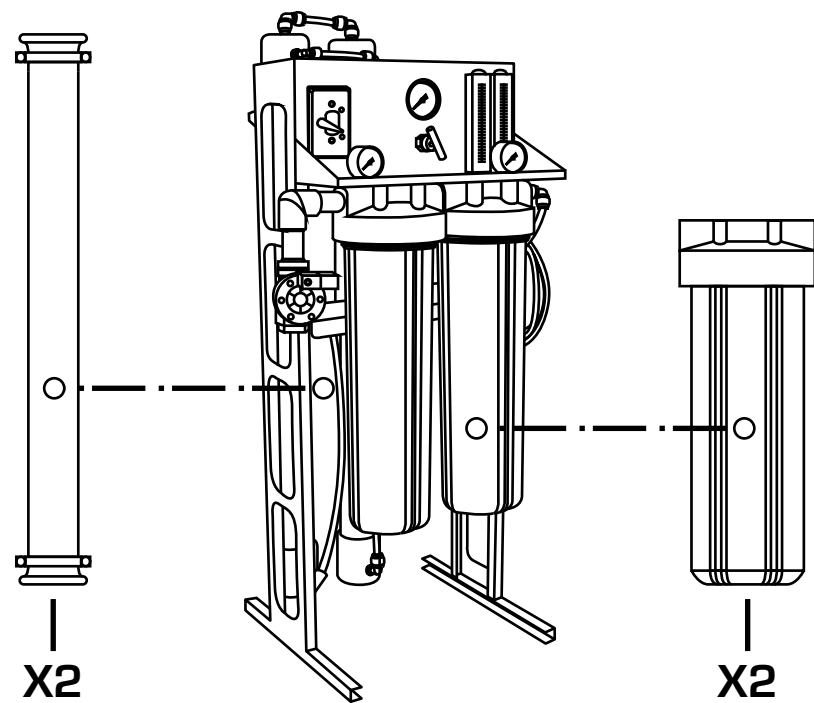

FLOW TYPE CHART	
INFLUENT WATER	— · — · — · — · — · — · — · — · —
SOFTENED WATER	- - - - -
WASTE WATER	.....

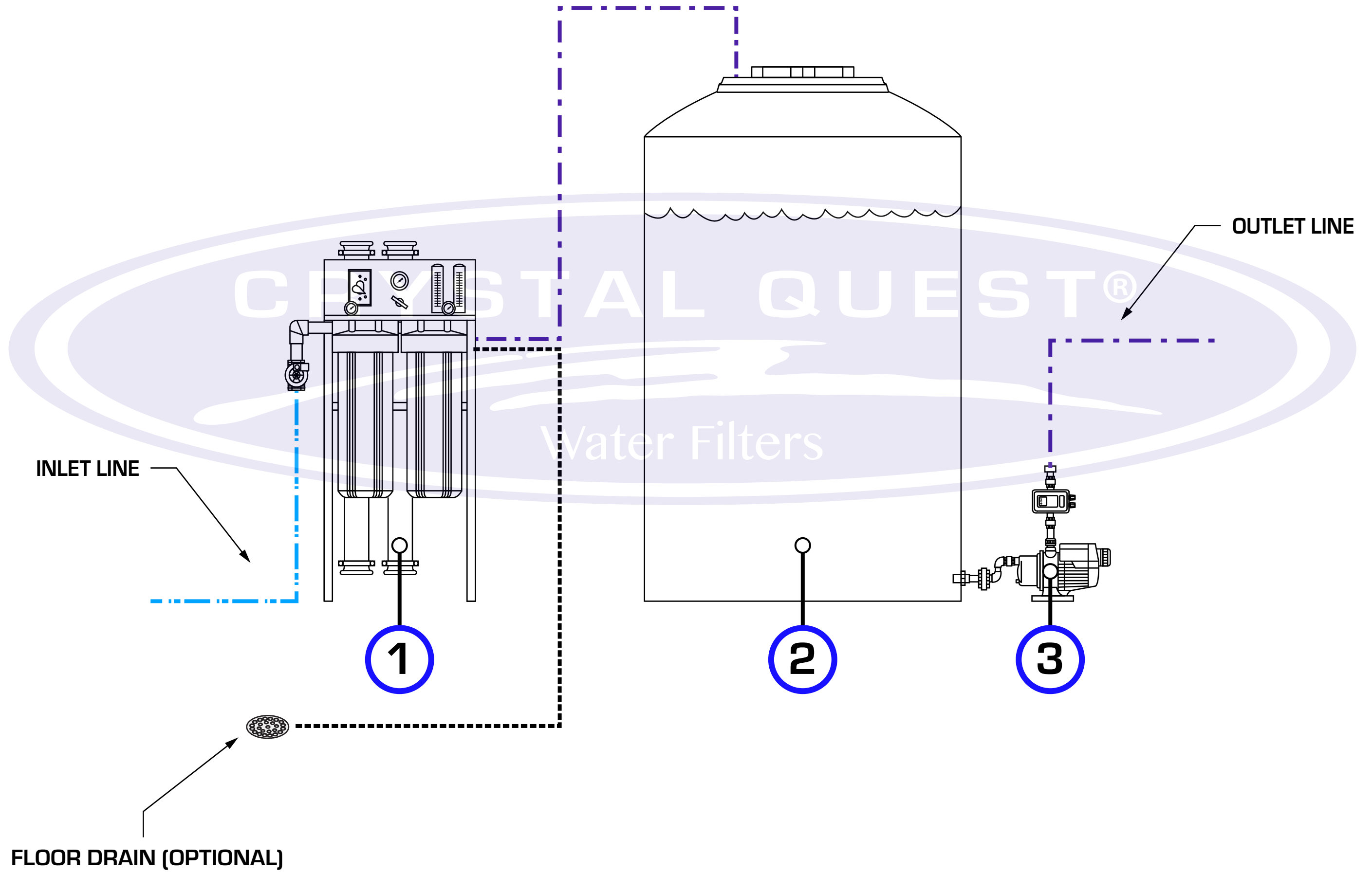

ORDER OF OPERATION:	PRODUCT SKU:	DIMENSIONS:	COMMENTS:	UNLESS OTHERWISE SPECIFIED:	DATE: 09/27/2018 DRAWN BY: DUSTIN	
①	1,500 GPD R.O. SYSTEM	CQE-CO-02026R L 14" x W 20" x H 46"	<ul style="list-style-type: none"> <li>• GPD IS PER 24-HOUR CYCLE.</li> <li>• RECOVERY RATIO MAY VARY FROM 33% - 50% AND UP TO 75% IF SYSTEM PROJECTIONS HAVE BEEN PROVIDED</li> </ul>	DIMENSIONS ARE IN INCHES. DRAWING IS NOT TO SCALE.	TITLE: <b>1,500 GPD REVERSE OSMOSIS SYSTEM WITH 220 GALLON STORAGE TANK</b>	
②	220 GAL STORAGE TANK	CQE-ST-00402 D 36" x H 55"				
③	REBOOSTERIZER PUMP	CQE-PT-03304 D 18" x W 11" x H 14"				
---	---	---	THE INFORMATION CONTAINED IN THIS DRAWING IS THE SOLE PROPERTY OF CRYSTAL QUEST. ANY REPRODUCTION IN PART OR AS A WHOLE WITHOUT THE WRITTEN PERMISSION OF CRYSTAL QUEST IS STRICTLY PROHIBITED.	<b>DIMENSION KEY:</b>		
---	---	---		L → LENGTH	SIZE C	DWG. NO. 1
---	---	---		W → WIDTH		REV # A
---	---	---		H → HEIGHT	SCALE: 1:20	WEIGHT:
---	---	---	D → DIAMETER		SHEET 1 OF 1	